

Native Pens

Euro Pen Instructions

Required:

1/4" Mandrel

7mm Drill Bit

Pen Mill

Euro Bushings

Pen Kit Parts:

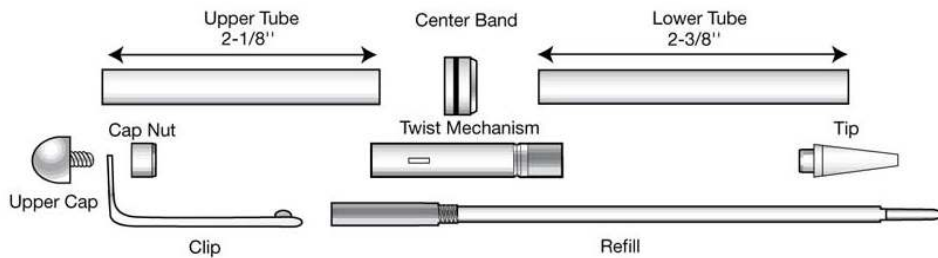

Turning the Pen Barrels.

1. Cut a pen blanks slightly longer than the brass tubes. Note, the upper and lower tubes are different lengths.
2. Drill the blanks through the centre, lengthwise, with a 7mm bit.
3. Sand the surface of the brass tube. This can be done by hand or mounted in the bushes on the lathe. This will clean off any oxidation and roughen the surface for a better glue bond.
4. Bond the tubes into the timber blanks. This can be done with CA or two-part epoxy glue. Insert the tube with a twisting motion then push it in until slightly under flush. About equal distance in from each end of the timber blank.
5. Allow glue to cure as required by glue manufacturer.
6. Clean all the dried glue from inside the brass tube. Not cleaning out all the glue from the tube is the most common cause of pen failure.
7. Using a Pen Mill, face off the ends of the blanks until you can just see the bright brass end of the tube. STOP facing at this point. Another method to square the ends is sanding on a disc sander against a square fence or using a jig to hold the tube square to the disc then lightly touching the end with the Pen Mill to finish them.
8. Once the blanks are square and you can see the ends of the tube brighten you can mount the blanks to the mandrel.

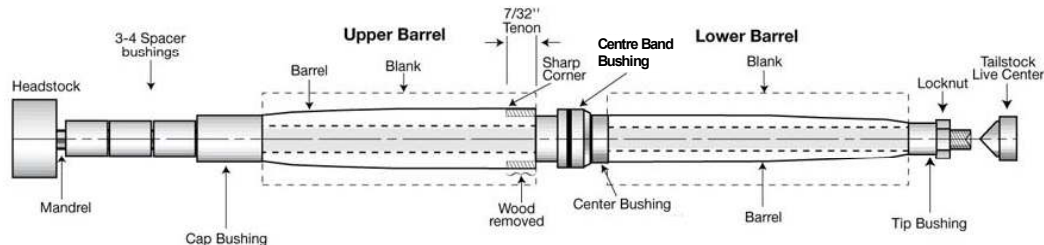

9. First, turn then sand the blanks down to the bushings, with the centre band bush ring fitted to the centre bushing.

Native Pens

Euro Pen Instructions

10. Remove the Centre Band Bushing then mark the Tenon position, $7/32''$ or 5.5mm back from the centre bushing.
11. Use a very fine parting tool to make the initial cut of the Tenon at the mark. Once done, turn down to the Centre bushing diameter. Ensure the Tenon shoulder is kept square.
12. Check the fit of the Centre Band over the tenon and over the lower barrel before finishing.
13. Finish the pen to your specifications. Remove the barrels from the mandrel and it is ready for assembly.

Assembly of the pen.

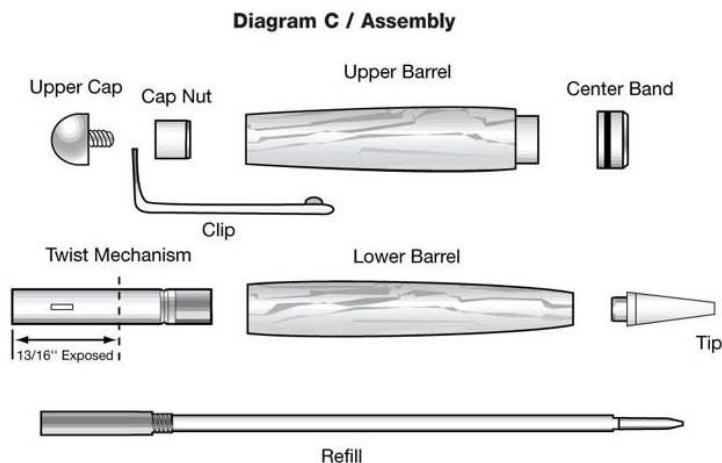

1. Press the cap nut into the small end of the Upper Barrel.
2. Using a drop of glue, bond the Centre Band onto the tenon. 5min epoxy works well here as it gives adequate time to ensure the Centre Band is aligned correctly. Allow glue to cure.
3. Thread the Upper Cap through the clip and into the Cap Nut and tighten.
4. Press the Tip into the Lower Barrels tapered end.
5. Press the transmission into the thick end of the Lower Barrel. Take care to press this in gradually, at stages screw in the refill to check the position of the exposed refill tip.
6. With a twisting motion, slide the upper barrel onto the transmission.
7. You pen is finished.